



# AGM LEAD ACID BATTERY

## BATTERIE PLOMB AGM

### 1.2-12 General Purpose FR F4.8

#### MAIN INFORMATION / INFORMATIONS GÉNÉRALES

BRAND / MARQUE	NX
TECHNOLOGY / TECHNOLOGIE	AGM Lead acid
NOMINAL VOLTAGE / TENSION NOMINALE	12V
NOMINAL CAPACITY / CAPACITÉ NOMINALE (C <sub>20</sub> , 1.75V/cell)	1.2Ah
DIMENSIONS (± 1 mm) / DIMENSIONS (± 1 mm)	
• Length / Longueur	97 mm (3.82 inches)
• Width / Largeur	43 mm (1.69 inches)
• Height / Hauteur	52 mm (2.04 inches)
• Total height with terminals / Hauteur totale (avec cosSES)	58 mm (2.28 inches)
WEIGHT (± 2 %) / POIDS (± 2 %)	Approx 0.52kg (1.15lbs)
TERMINAL / TYPE DE COSSES	F4.8 = FASTON 4.8
CASING / TYPE DE BAC	UL94 V-0 (Flame retardant)



#### TECHNICAL INFORMATION / INFORMATIONS TECHNIQUES

CAPACITY / CAPACITÉ	1.20Ah/0.060A (20hr, 1.75V/cell, 25°C/77°F)
	1.13Ah/0.113A (10hr, 1.75V/cell, 25°C/77°F)
	1.04Ah/0.207A (5hr, 1.75V/cell, 25°C/77°F)
	0.92Ah/0.306A (3hr, 1.75V/cell, 25°C/77°F)
	0.79Ah/0.789A (1hr, 1.60V/cell, 25°C/77°F)
DISCHARGE CURRENT / COURANT DE DÉCHARGE	18A (5s)
INTERNAL RESISTANCE / RÉSISTANCE INTERNE	Approx 145mΩ
OPERATING TEMPERATURE RANGE / PLAGE DE TEMPÉRATURE	
• Discharging / Décharge	-15°~50°C (5 ~122°F)
• Charging / Charge	-20°~40°C (-4 ~104°F)
• Storage / Stockage	-15°~40°C (5 ~104°F)
NOMINAL OPERATING TEMPERATURE / TEMPÉRATURE D'UTILISATION	25 ± 3°C (77 ± 5°F)
CAPACITY VS TEMPERATURE / CAPACITÉ SELON LA TEMPÉRATURE	
	40°C (104°F) 103%
	25°C (77°F) 100%
	0°C (32°F) 86%

#### Terminal

Unité : mm / Unit: inches

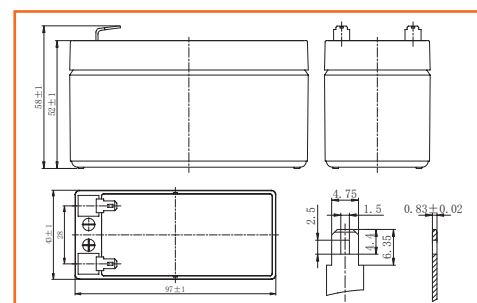

APPLICATIONS / APPLICATIONS

All purpose / Tout usage

Aircraft signal / Signal d'avion

UPS / Onduleur

Electronic devices and equipment / Appareils et équipements électroniques

Emergency light / Éclairage de secours

Emergency backup / Alimentation de secours

Railway signal / Signalisation ferroviaire

Power supply / Réserve d'énergie

Alarm and security system / Alarme et sécurité

CONSTANT CURRENT DISCHARGE CHARACTERISTICS / CARACTÉRISTIQUES DE DÉCHARGE À COURANT CONSTANT

FV/Time	5min	10min	15min	20min	30min	45min	1h	1.5h	2h	3h	4h	5h	6h	8h	10h	20h
1.85V/cell	3.73	2.28	1.78	1.48	1.10	0.813	0.714	0.523	0.411	0.296	0.236	0.201	0.172	0.136	0.111	0.059
1.80V/cell	4.01	2.42	1.86	1.54	1.14	0.835	0.731	0.534	0.418	0.301	0.240	0.204	0.175	0.138	0.112	0.059
1.75V/cell	4.23	2.52	1.92	1.59	1.17	0.853	0.746	0.543	0.426	0.306	0.243	0.207	0.177	0.139	0.113	0.060
1.70V/cell	4.58	2.62	1.99	1.63	1.20	0.872	0.760	0.553	0.432	0.311	0.246	0.209	0.179	0.141	0.115	0.060
1.67V/cell	4.58	2.69	2.04	1.67	1.22	0.886	0.771	0.560	0.437	0.314	0.249	0.211	0.181	0.142	0.115	0.060
1.60V/cell	4.86	2.80	2.11	1.72	1.25	0.908	0.789	0.572	0.446	0.319	0.253	0.215	0.183	0.144	0.117	0.062

Units: Amperes (25°C, 77°F)

CONSTANT POWER DISCHARGE CHARACTERISTICS / CARACTÉRISTIQUES DE DÉCHARGE À PUISSANCE CONSTANTE

FV/Time	5min	10min	15min	20min	30min	45min	1h	1.5h	2h	3h	4h	5h	6h	8h	10h	20h
1.85V/cell	7.06	4.34	3.40	2.86	2.13	1.58	1.39	1.02	0.804	0.583	0.465	0.397	0.341	0.269	0.220	0.117
1.80V/cell	7.52	4.57	3.55	2.96	2.19	1.61	1.42	1.04	0.817	0.591	0.471	0.402	0.345	0.273	0.223	0.119
1.75V/cell	7.84	4.72	3.64	3.02	2.23	1.64	1.44	1.05	0.830	0.599	0.477	0.407	0.349	0.275	0.225	0.120
1.70V/cell	8.12	4.87	3.74	3.09	2.28	1.67	1.46	1.07	0.840	0.607	0.483	0.412	0.353	0.278	0.227	0.121
1.67V/cell	8.34	4.98	3.82	3.15	2.32	1.70	1.48	1.08	0.848	0.612	0.487	0.415	0.356	0.280	0.229	0.122
1.60V/cell	8.68	5.13	3.93	3.23	2.37	1.73	1.51	1.10	0.862	0.621	0.494	0.420	0.360	0.284	0.232	0.123

Units: Amperes (25°C, 77°F)

DISCHARGE CHARACTERISTICS (25°C)  
CARACTÉRISTIQUES DE DÉCHARGE

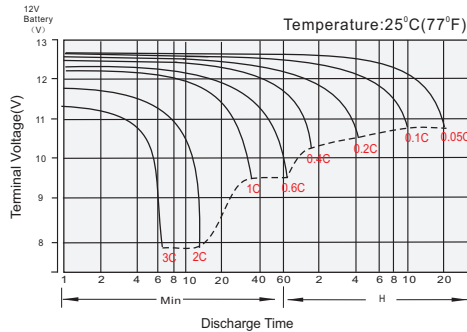

FLOAT CHARGING CHARACTERISTICS  
CARACTÉRISTIQUES DE CHARGE EN FLOATING

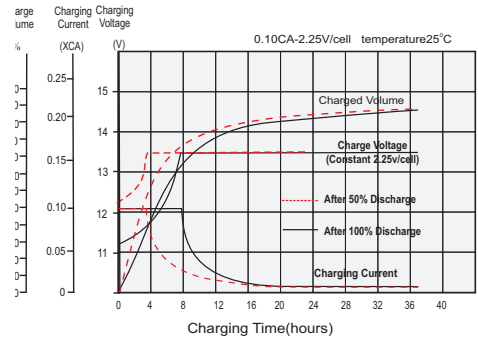

TEMPERATURE EFFECTS IN RELATION TO BATTERY CAPACITY  
EFFETS DE LA TEMPÉRATURE SUR LA CAPACITÉ DE LA BATTERIE

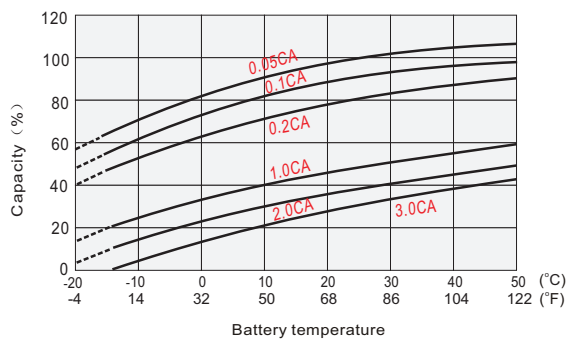

EFFECT OF TEMPERATURE ON LONG TERM FLOAT LIFE  
EFFET DE LA TEMPÉRATURE SUR LA DURÉE DE VIE EN FLOATING À LONG TERME

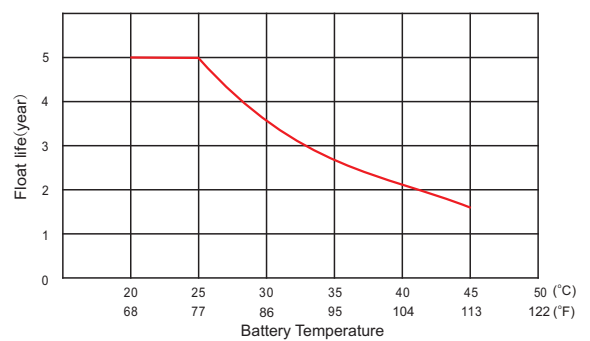

OUTLINE SAFETY WARNING: USE ONLY WITH IN THE ALLOWED PARAMETERS. Do not short circuit or over-load the battery. Charge only using an approved charger designed specifically to charge this battery. Do not heat above maximum temperatures indicated. Never crush, mutilate, puncture or abuse the battery. Do not dismantle the pack or disable any of the protective devices or circuits. DO NOT USE THE BATTERY IF YOU SUSPECT IT MAY BE FAULTY OR DAMAGED.

© Copyright Enix Energies 2005. NB: This document and the product design are the intellectual property of Enix Energies. No document or design may be copied or used for commercial purposes without written permission of Enix Energies. Users must satisfy themselves, by means of testing etc, that products are suitable for their application. Data in this document is for general guidance only; consult cell manufacturers data for definitive information. Information is given free of charge and in good faith, but no responsibility can be accepted for any errors or omission or costs or losses or liabilities arising from the use of this information. All business is conducted to Enix Energies terms and conditions only.