

## SPECIFICATION FOR VT FL 70

---

### CONTENTS

- 1/ SCOPE
- 2/ GENERAL ELECTRICAL CHARACTERISTICS
- 3/ GENERAL MECHANICAL CELL SPECIFICATION
- 4/ CAPACITY
- 5/ CHARGE RECOMMENDATIONS
- 6/ CYCLE LIFE
- 7/ CELL AND BATTERY MANAGEMENT
- 8/ SPECIFICATION APPROVALS

## SPECIFICATION FOR VT FL 70

### 1/ SCOPE

This specification applies to a Nickel-Cadmium cylindrical rechargeable single cell which ARTS Energy designates as VT FL 70. This cell belongs to the ARTS Energy High temperature Ni-Cd cell series and has been designed for permanent charge applications at very high temperature (up to 55°C).

In term of technology, the cell is built with:

- Foam positive electrode
- Plastic bonded negative electrode (PBE)
- All external metallic components are nickel plated steel

### 2/ GENERAL ELECTRICAL CHARACTERISTICS

All the figures listed in the following tables are based on fresh single cells.  
Tests carried out in accordance with international standard document IEC 61951-1.

## SPECIFICATION FOR VT FL 70

ITEM	SPECIFICATION	UNITS	NOTES
<b>MAIN CHARACTERISTICS</b>			
cell designation	VT FL 70		
IEC cell designation	KRMT 33/90		
Nominal voltage	1.2	Volt	As per IEC 61951-1
Minimum IEC capacity	7000	mAh	
Typical impedance	10	mOhm	At 1000 Hz
<b>CHARGE CURRENT</b>			
Standard	700	mA	Timer is mandatory
Permanent	350	mA	
<b>CHARGE DURATION</b>			
Standard	16	hours	Timer is mandatory
<b>DISCHARGE CURRENT</b>			
Maximum continuous current	21	A	Max end of discharge voltage 0.8V/cell
<b>Charge Retention</b> 28 days at. 20°C+/-2°C	>70	%	Storage in fully charged state discharged at C/5
<b>TEMPERATURE RANGE</b>			
In charge	+5/+55	°C	
In discharge 21 A max	+5/+55	°C	
In storage			See § 7
Recommended	+5/+25	°C	
Low limit range	-40 to +5	°C	Shorter than 1 month
High limit range	+25 to +60	°C	Shorter than 1 month
<b>TYPICAL WEIGHT</b>			
	190	g	

## SPECIFICATION FOR VT FL 70

### 3/ GENERAL MECHANICAL CELL SPECIFICATION

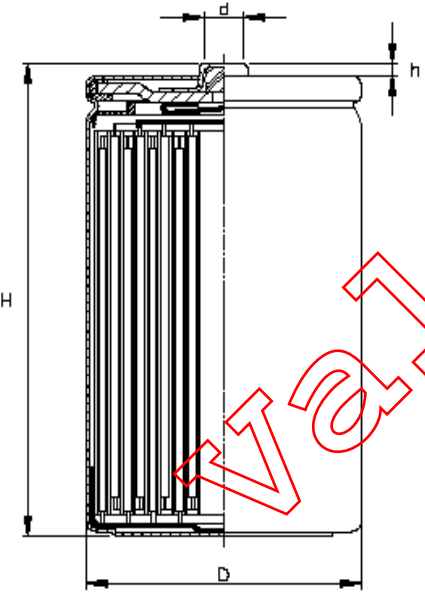
BARE CELL DRAWING	BARE CELL DIMENSIONS (mm)
	<p><b>Diameter:</b> <math>D = 32.15 \pm 0.1</math></p> <p><b>Height:</b> <math>H = 88 \pm 0.5</math></p> <p><b>Positive contact</b></p> <p><b>Flat area diameter:</b> <math>d = 8</math></p> <p><b>Overstep:</b> <math>h = 2</math></p>

## SPECIFICATION FOR VT FL 70

### 4/ CAPACITY

IEC Capacity is defined as required in IEC 61951-1 (§7.3.2)

- Temperature:  $+20^{\circ} \pm 5^{\circ}\text{C}$
- Charge current: 700 mA constant current (C/10)
- Charge duration: 16 hours
- Period of res : 1 hour
- Discharge current: 1400 mA constant current (C/5)

Minimum capacity: 7000 mAh

5 cycles are allowed to get the specified value.

### 5/ CHARGE RECOMMENDATIONS

#### Standard charge:

With standard charge rate (C/10) a timer is mandatory to stop the charge.

#### Permanent charge:

The VT FL 70 cell is designed to be permanently charged between  $+5^{\circ}\text{C}$  to  $+55^{\circ}\text{C}$  with above mentioned constant current (C/20). Charging at the occasional temperature range of  $0^{\circ}\text{C}$  to  $+5^{\circ}\text{C}$  and  $+55^{\circ}\text{C}$  to  $+70^{\circ}\text{C}$  is accepted for short durations only (< 1 month). For a usage at temperatures lower than  $0^{\circ}\text{C}$  it is mandatory to limit the charge voltage at 1.65V per cell.

In case of pulsed charge at rate <50Hz, it is mandatory to avoid rest period >1s.

## SPECIFICATION FOR VT FL 70

### 6/ CYCLE LIFE

Cycle Life duration of a VT FL 70 cell or battery pack depends mainly on the cell or battery pack temperature and overcharged capacity. Minimum life duration of a VT FL 70 cell/battery is 4 years with the average operating condition of:

Temperature:	up to +55° +/- 2°C
Permanent Charge current:	350 mA constant current (C/20)
Discharge:	1 per month (at 0.5C rate. Maximum) (1V/cell cut-off)

**The VT FL 70 cell is designed to comply with the normative permanent charge endurance test described in the IEC 61951-1 standard.**

This performance is mandatory for use in Emergency Lighting Units to comply with the IEC 60598 2.22.

### 7/ CELL AND BATTERY MANAGEMENT

- Overcharge:

As it has been designed to be permanently overcharged, the VT FL 70 can accept occasional overcharge up to C/10 (700 mA) without damage. With a timer or a coulomb counter.

- Over discharge:

A deep discharge or “over discharge “damages the cell performance so it is recommended to manage the discharge with appropriate cut-off systems (1,0V/cell), and to avoid letting the cell / battery connected to the equipment for a long period (> 1month).

After this cut-off, it is mandatory that the “leakage current” due to electronic consumption be lower than 100 µA.

During the beginning of the first charge following over discharge, the voltage can exceed the maximum allowed value.

## SPECIFICATION FOR VT FL 70

---

- Storage:

- Normal conditions:

ARTS Energy recommends to store the cell or battery pack within a temperature range of +5° to +25°C in a 65 ± 5% relative humidity atmosphere.

- Long term storage (up 6 months):

Long term storage leads to battery self discharge and deactivation of chemical components. ARTS Energy recommends storing for a long period between 5°C and 25°C.

In such case, it is recommended to partially recharge the cells/battery each 6 months. In addition, when using the cells/batteries for the first time after 6 months storage, in order to restore the initial cell performances, it is recommended to full cycle the cell/battery (maximum 5 cycles). In these conditions, the VT FL 70 cell shall recover 90% of its initial capacity.

- Service life:

When a cell or battery pack is used under normal conditions as described above, the VT FL 70 cell or battery pack will last 4 years. Failure in charging, discharging, storage or temperature range can reduce the service life and damage the cell performances.

- Battery assembly:

Consult ARTS Energy for advice in pack assembly and charge and discharge management. The way of using the battery must strictly be in accordance with ARTS Energy technical recommendations, to obtain the performances announced by ARTS Energy.

## SPECIFICATION FOR VT FL 70

---

8/ SPECIFICATION APPROVALS
----------------------------

TECHNICAL Manager:

I. Francisco



MARKETING Manager:

J. Penigaud



QUALITY Manager:

P. Perroy



VALIDE