



# AGM LEAD ACID BATTERY

## 160-12 General Purpose M8-F



### MAIN INFORMATION / INFORMATIONS GÉNÉRALES

<b>BRAND / MARQUE</b>	NX
<b>TECHNOLOGY / TECHNOLOGIE</b>	AGM Lead acid
<b>NOMINAL VOLTAGE / TENSION NOMINALE</b>	12V
<b>NOMINAL CAPACITY / CAPACITÉ NOMINALE</b>	160Ah (20hr)
<b>DIMENSIONS (± 2 mm) / DIMENSIONS (± 2 mm)</b>	
• <b>Length / Longueur</b>	483 ± 3mm (19.0 inches)
• <b>Width / Largeur</b>	170 ± 3mm (6.69 inches)
• <b>Height / Hauteur</b>	239 ± 3mm (9.39 inches)
• <b>Total height with terminals / Hauteur totale (avec cosses)</b>	239 ± 3mm (9.39 inches)
<b>WEIGHT (± 2 %) / POIDS (± 2 %)</b>	Approx 43.5kg (95.9lbs)
<b>TERMINAL / TYPE DE COSSES</b>	M8-F = M8 FEMALE
<b>CASING / TYPE DE BAC</b>	UL94 HB (Standard ABS)
<b>COLOR / COULEUR DE BAC</b>	Black top and black case



### TECHNICAL INFORMATION / INFORMATIONS TECHNIQUES

<b>CAPACITY / CAPACITÉ</b>	160.0Ah/7.80A (20hr, 1.80V/cell, 25°C/77°F) 150.0Ah/15.0A (10hr, 1.80V/cell, 25°C/77°F) 129.0Ah/25.8A (5hr, 1.75V/cell, 25°C/77°F) 117.0Ah/39.0A (3hr, 1.75V/cell, 25°C/77°F) 91.5Ah/91.5A (1hr, 1.60V/cell, 25°C/77°F)
<b>DISCHARGE CURRENT / COURANT DE DÉCHARGE</b>	1500A (5s)
<b>INTERNAL RESISTANCE / RÉSISTANCE INTERNE</b>	Approx 3.5mΩ
<b>OPERATING TEMPERATURE RANGE / PLAGES DE TEMPÉRATURE</b>	
• <b>Discharging / Décharge</b>	-15°~50°C (5 ~122°F)
• <b>Charging / Charge</b>	0°~40°C (32 ~104°F)
• <b>Storage / Stockage</b>	-15°~40°C (5 ~104°F)
<b>NOMINAL OPERATING TEMPERATURE / TEMPÉRATURE D'UTILISATION</b>	25 ± 3°C (77 ± 5°F)
<b>CAPACITY VS TEMPERATURE / CAPACITÉ SELON LA TEMPÉRATURE</b>	40°C (104°F) 103% 25°C (77°F) 100% 0°C (32°F) 86%

#### Terminal

Unité : mm / Unit: inches

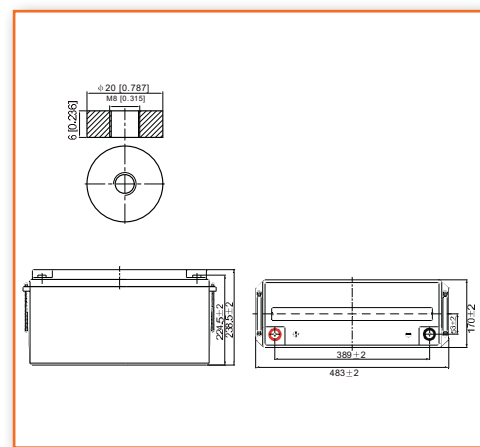

### APPLICATIONS

All purpose / Tout usage

UPS / Onduleur

Emergency light / Éclairage de secours

Railway signal / Signalisation ferroviaire

Alarm and security system / Alarme et sécurité

Aircraft signal / Signal d'avion

Electronic devices and equipment / Appareils et équipements électroniques

Emergency backup / Alimentation de secours

Power supply / Réserve d'énergie

**TMD 1 Description, classe :** UN 2800 – accumulateurs inversables remplis d'électrolyte liquide, 8, none, (E)

**ADR :** Not regulated

**IMDG** Not regulated

**IATA :** Exempt

**Procédure TMD PROC 2 :** UN 2800



**CONSTANT CURRENT DISCHARGE (AMPERES) AT 25°C**  
**TABLE DE DÉCHARGE À COURANT ET PUISSANCE CONSTANTS (A) À 25°C**

F.V/Temps	5min	10min	15min	20min	30min	45min	1h	2h	3h	4h	5h	6h	8h	10h	20h
1.85V/cell	256.7	201.8	171.6	143.6	114.1	86.4	70.7	45.0	35.6	29.1	23.5	20.4	16.6	14.2	7.73
1.80V/cell	344.6	257.9	207.4	169.7	134.6	100.4	79.2	49.2	38.3	31.1	25.2	21.9	17.6	15.0	7.80
1.75V/cell	388.5	283.4	226.5	182.6	139.8	104.2	82.9	51.0	39.0	31.8	25.8	22.5	17.9	15.1	7.88
1.70V/cell	427.9	308.9	241.8	191.9	145.5	108.4	85.5	53.0	40.1	32.6	26.5	23.0	18.1	15.3	8.03
1.65V/cell	471.8	333.3	257.2	203.8	153.5	111.1	88.4	54.5	41.8	33.7	27.2	23.5	18.4	15.6	8.13
1.60V/cell	/	361.9	275.0	217.1	162.0	115.8	91.5	56.3	43.1	34.8	28.1	24.0	18.6	15.8	8.18

**CONSTANT POWER DISCHARGE (WATTS) AT 25°C**  
**DÉCHARGE À PUISSANCE CONSTANTE (WATTS) À 25°C**

F.V/Temps	5min	10min	15min	20min	30min	45min	1h	2h	3h	4h	5h	6h	8h	10h	20h
1.85V/cell	469.4	372.8	320.3	270.6	217.5	166.0	136.4	87.5	69.4	56.9	46.0	40.1	32.7	28.0	15.3
1.80V/cell	623.4	470.8	381.8	315.2	252.7	191.6	152.0	94.8	74.3	60.4	49.1	42.9	34.6	29.6	15.4
1.75V/cell	687.9	509.0	411.9	335.8	260.2	196.9	158.3	98.0	75.4	61.5	50.3	43.9	35.1	29.9	15.6
1.70V/cell	736.5	542.2	433.6	350.3	269.3	204.0	162.7	101.7	77.3	63.0	51.4	44.8	35.6	30.2	15.8
1.65V/cell	800.6	579.8	457.5	369.3	281.8	207.2	167.0	103.9	80.2	65.0	52.7	45.6	36.1	30.7	16.0
1.60V/cell	/	615.1	481.2	389.2	295.4	214.8	172.0	106.9	82.3	66.8	54.2	46.5	36.3	31.0	16.1

**DISCHARGE CHARACTERISTICS**  
**CARACTÉRISTIQUES DE DÉCHARGE**

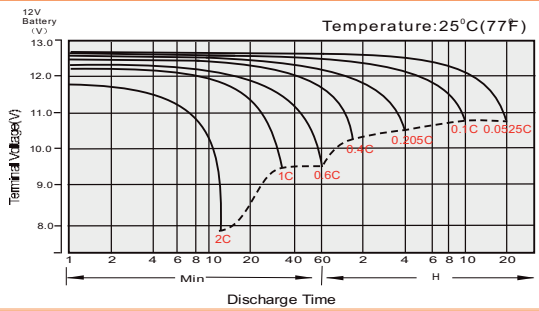

**FLOAT CHARGING CHARACTERISTICS**  
**CARACTÉRISTIQUES DE CHARGE EN FLOATING**

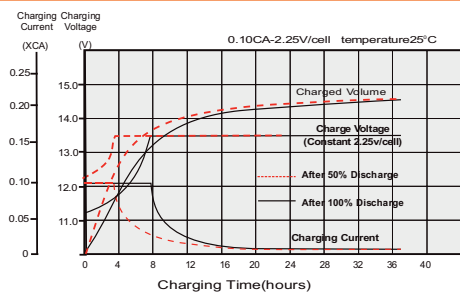

**TEMPERATURE EFFECTS IN RELATION TO BATTERY CAPACITY**  
**EFFET DE LA TEMPÉRATURE SUR LA BATTERIE**

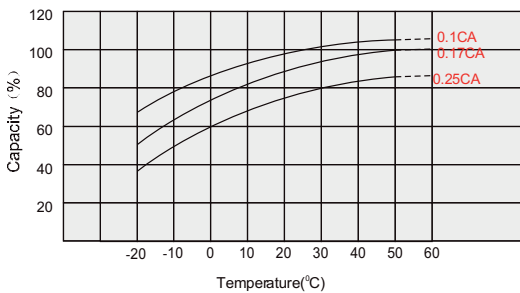

**EFFECT OF TEMPERATURE ON LONG TERM FLOAT LIFE**  
**EFFET DE LA TEMPÉRATURE SUR LA DURÉE DE VIE EN FLOATING**

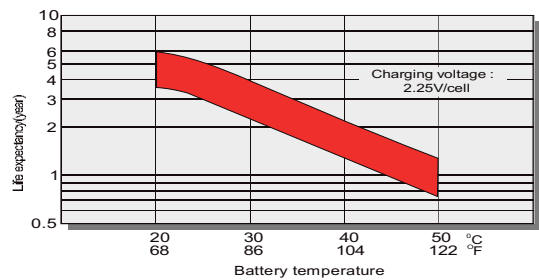

**CYCLE LIFE IN RELATION TO DEPTH OF DISCHARGE**  
**CYCLE DE VIE EN FONCTION DE LA PROFONDEUR DE LA DÉCHARGE**

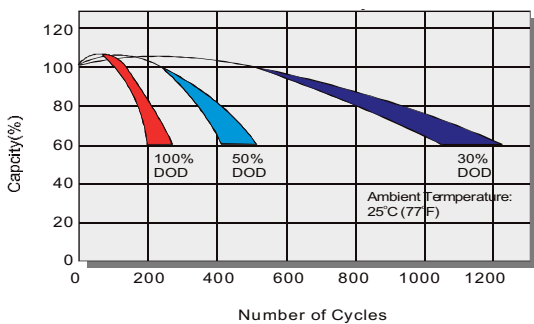

**SELF DISCHARGE CHARACTERISTICS**  
**RELATION ENTRE LA CAPACITÉ ET LE TEMPS DE STOCKAGE**

