

**ROMBAT TECHNICAL DATA SHEET – L1 50Ah 400A PILOT**

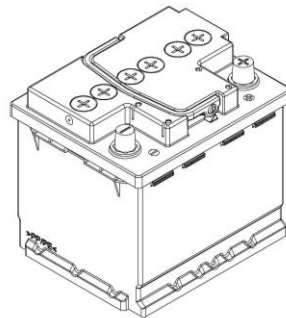
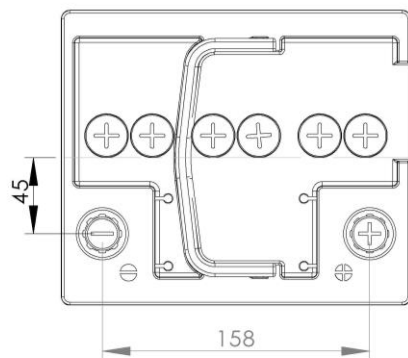
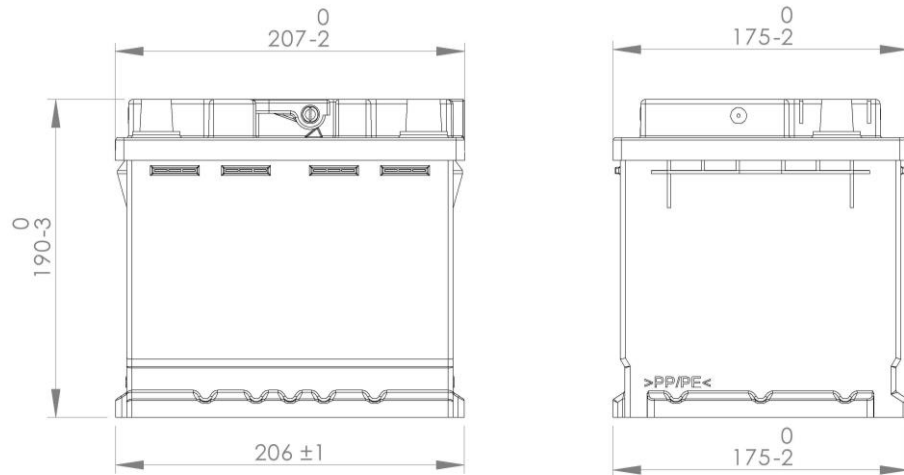

**MANUFACTURER: S.C. ROMBAT S.A.**

**CODE: P150**

**APPLICATION: Auto**

**BRAND: PILOT**

**SPECIFICATION: 12V - 50Ah - 400A (EN)**

**TERMINAL POSITION: 0 (positive right)**

**SIZE (LxIhx): 207x175x190 (mm)**

**BOX TYPE: L1, PPCo, bottom hold down 10.5 mm – B13 (4 sides)**

**LID TYPE: PPCo Kamina lid with right side central venting hole, flame arrestor, M18 plugs and IHL (integrated handle to cover)**

**ELECTROLYTE DENSITY ON DELIVERY: 1.28 ± 0.01 g/cm<sup>3</sup>**

**WATER LOST: Very Low**

**SEPARATOR: Polyethylene 0.9 mm**

**PACKAGING: 60 pieces/euro pallet (1200x800 mm)**

**SHIPMENT REGULATION:**

- Normal for road transportation
- Special condition 8 class hazard UN2794 for sea transportation

