

ROMBAT TECHNICAL DATA SHEET – L5 95Ah 750A PILOT

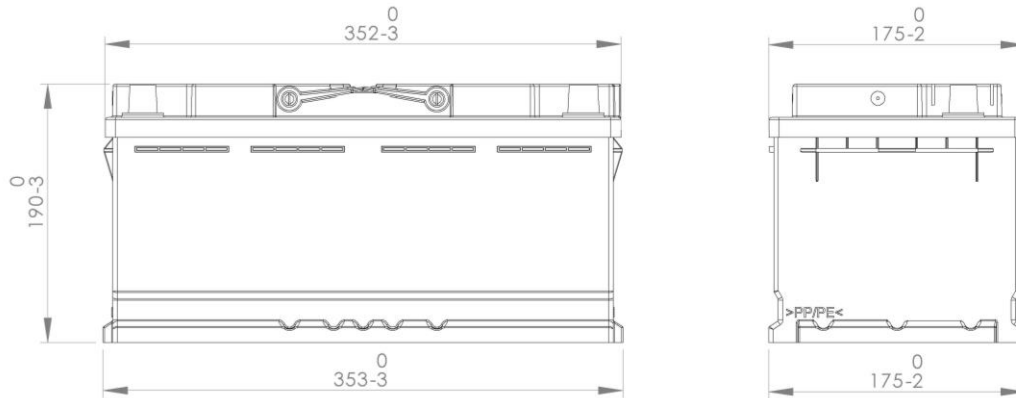

MANUFACTURER: S.C. ROMBAT S.A.

CODE: P595

APPLICATION: Auto

BRAND: PILOT

SPECIFICATION: 12V - 95Ah - 750A (EN)

TERMINAL POSITION: 0 (positive right)

SIZE (LxIhx): 353x175x190 (mm)

BOX TYPE: L5, PPCo, bottom hold down 10.5 mm – B13 (4 sides)

LID TYPE: PPCo Kamina lid with right side central venting hole, flame arrestor, M18 plugs and IHL (integrated handle to cover)

ELECTROLYTE DENSITY ON DELIVERY: 1.28 ± 0.01 g/cm³

WATER LOST: Very Low

SEPARATOR: Polyethylene 0.9 mm

PACKAGING: 36 pieces/euro pallet (1200x800 mm)

SHIPMENT REGULATION:

- Normal for road transportation
- Special condition 8 class hazard UN2794 for sea transportation

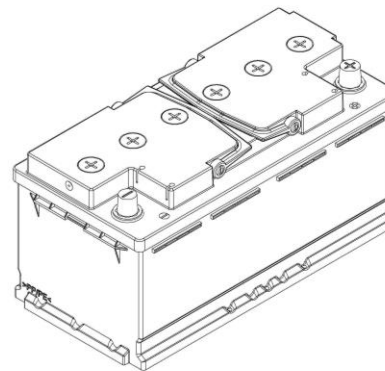
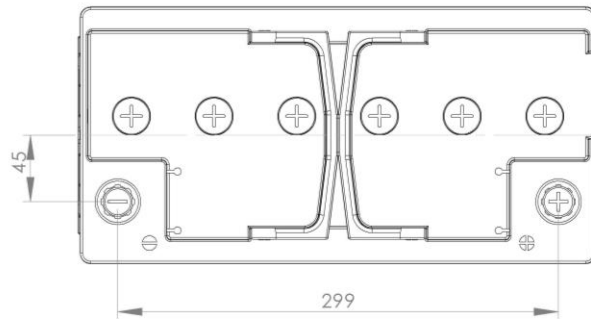

TERMINALS

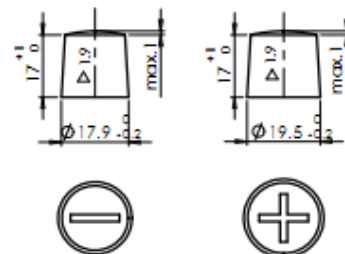

E: rombat@rombat.ro Drumul Cetății 4, Bistrița
T: +40 263 238 142 Bistrița-Năsăud
F: +40 263 234 010 4201 29, România

www.facebook.com/baterii.rombat
www.rombat.ro