



ALKALINE BATTERY NX-POWER TECH

PILE ALCALINE NX-POWER TECH

Une marque d'UP ENERGY

MAIN INFORMATION / INFORMATIONS GÉNÉRALES

SIZE	FORMAT	3LR12
BRAND NAME	MARQUE	NX
TECHNOLOGY	TECHNOLOGIE	Alkaline / Alcaline
CHEMICAL SYSTEM	SYSTÈME CHIMIQUE	Zn/KOH-H ₂ O/MnO ₂
VOLTAGE	TENSION	4.5V
CAPACITY	CAPACITÉ	4400mAh
WEIGHT	POIDS	160 Gr.
SHELF LIFE*	DURÉE DE VIE*	5 years / 5 ans
OPERATING TEMPERATURE RANGE	PLAGE DE TEMPÉRATURE	-18°C / +50°C
STORAGE TEMPERATURE RANGE	PLAGE DE TEMPÉRATURE DE STOCKAGE	10°C / +25°C

*In consideration of typical loss of capacity at storage. *Dans les conditions normales de stockage.



DIMENSIONS / DIMENSIONS

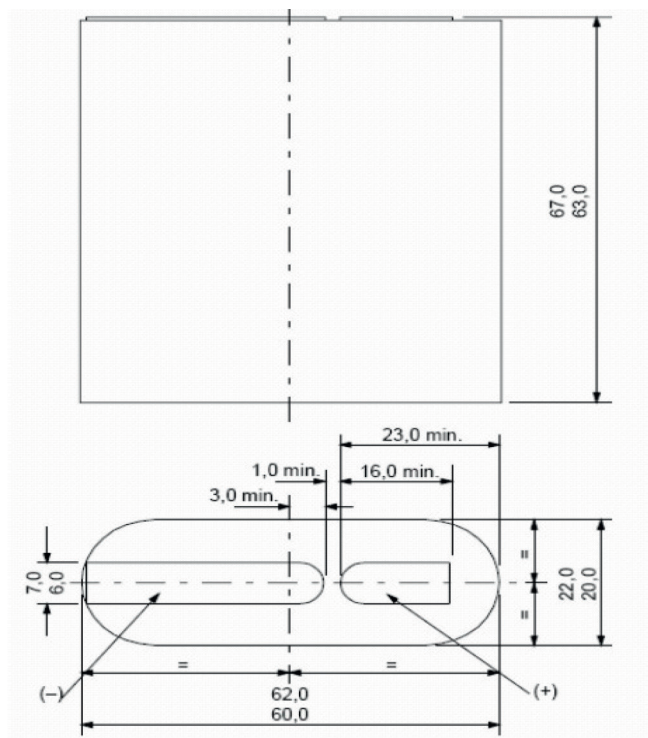

DISCHARGE DIAGRAM / COURBES DE DÉCHARGE

