

Battery Master Switch

Single Pole 350A

CODE NUMBER: 500015

GENERAL

Environmentally sealed to IP67 rating for high protection.

Fixed, heavy-duty die cast handle is non-removable.

ELECTRICAL

Rated Voltage: 48VDC maximum

Rated Current: 350/3500 Amps sustained/5 secs

Configuration: Normally Open (N/O)

PHYSICAL

Termination: M10 copper studs

Stud Torque: 15 ± 1.0 Nm

Contacts: Copper

Hardware: Brass nuts and washers

Construction: Zinc die cast body with reinforced plastic base and aluminium die cast T handle.

Environmental: IP67

Operating Temp: -40°C to $+85^{\circ}\text{C}$

Dimensions: 92mmL x 90mmW x 135mmH

Weight (nominal): 710 Grams

SPARE PARTS

With dependent auxiliary circuit: Order no. 500016

With independent auxiliary circuit: Order no. 500017



A heavy duty device for switching super high current in automotive, commercial and industrial vehicle applications. Featuring sealed construction, robust die cast housing, die cast T handle, all in a compact housing.

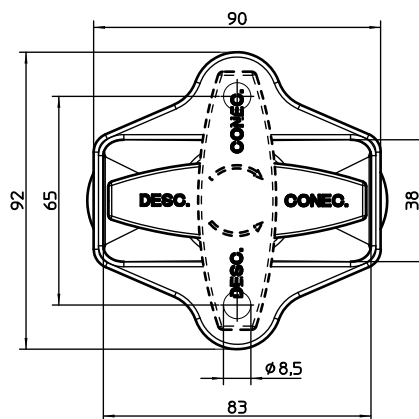
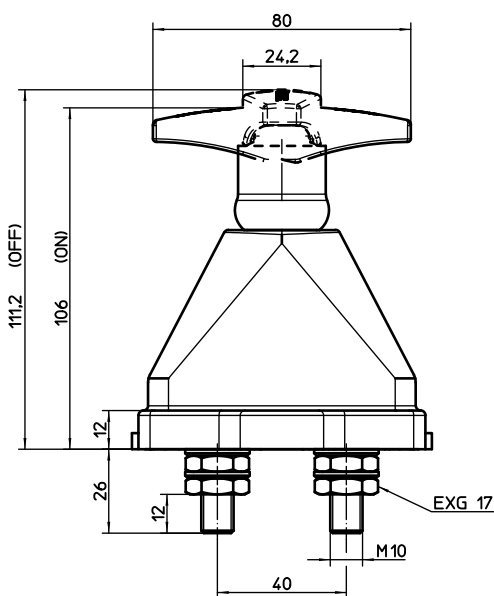

Connection

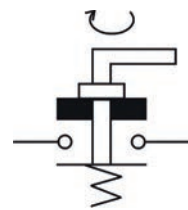

Fixing

